

FACTORY CODE: 22023116000141

BZ33-INV48OUT2-J

.3586767

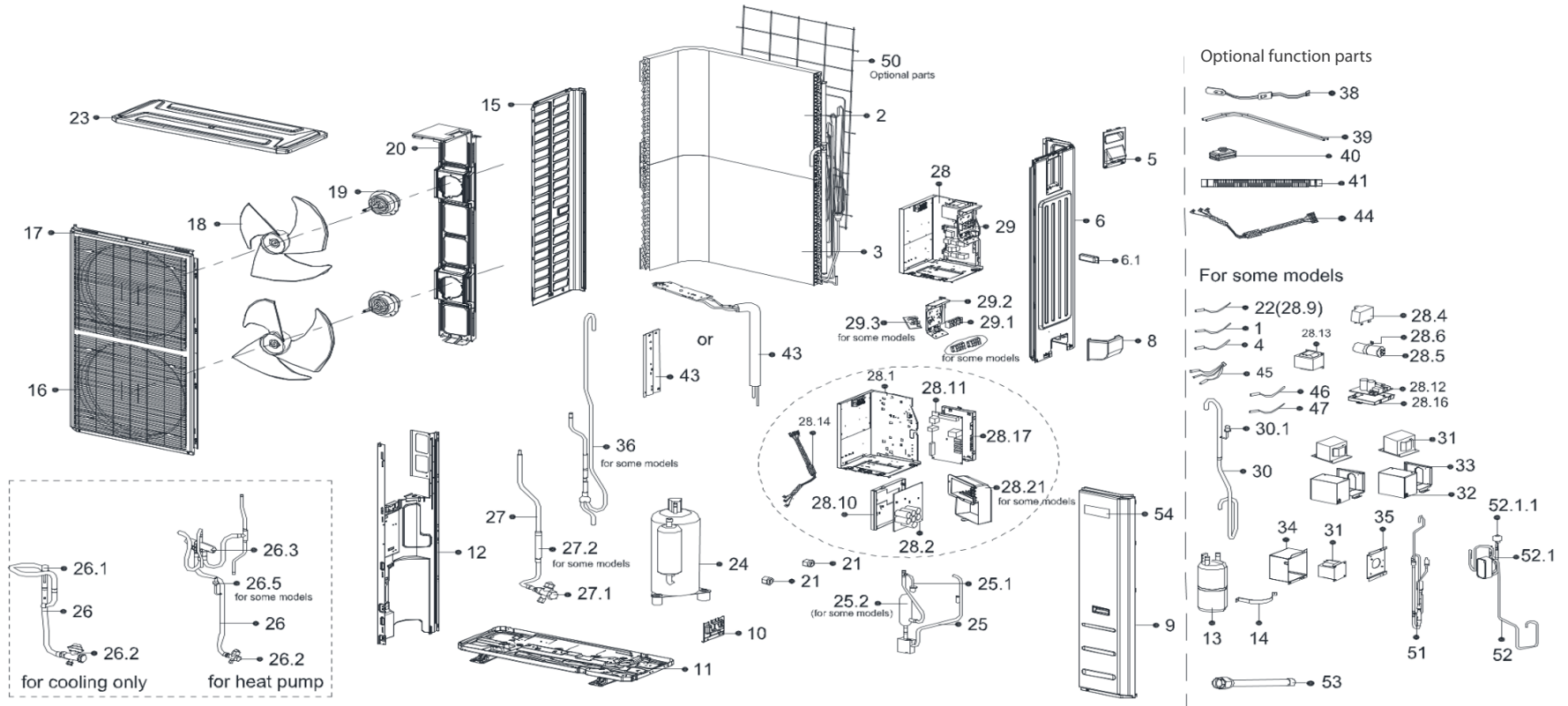



INVERTER REPLACEMENT PARTS GUIDE

BZ33-INV48OUT2-J

.3586767

Part #	Replacement Part	Part Name	Qty
1	11201007003425	Room temperature sensor	1
2	15822200001058	Condenser assembly	1
3	15822200004208	Condenser assembly	1
4	11201007003441	Pipe temperature sensor	1
5	12222000013365	Big handle assembly	1
6	12222000012373	Rear right clapboard assembly	1
6.1	12100702000038	Handle	1
8	12122000014023	Water collector	1
9	12222000006287	Front right clapboard assembly	1
10	12222200002361	Valve plate	1
11	12222000006290	Chassis assembly	1
12	12222000005733	Partition board assembly	1
13	15500508000009	Liquid-storage tank	1
15	12222200002363	Left side plate assembly of cabinet	1
16	12222000014845	Air outlet grille	2
17	12222000007564	Front panel	1
18	12100105000022	Axial flow fan	2
19	11002015009825	Brushless DC motor	2
20	12222000006288	Supporter subassembly of fan motor	1
21	15500406000008	Copper nut	1
21	15500406000010	Copper nut	1
22	11201007003124	Discharge temperature sensor	1
23	12222200002359	Top cover assembly	1
24	11103020006279	DC inverter rotary compressor	1
25	15122000026158	Discharge pipe assembly	1
25.1	17400516000851	Pressure controller	1
26	15422000022539	4-Way valve assembly	1
26.2	15500204000482	Gas valve	1
26.3	15500216000681	Four-way valve	1
26.5	11201008000773	Pressure sensor	1

Part #	Replacement Part	Part Name	Qty
27	15422000021392	Liquid valve assembly	1
27.1	15500204000021	Gas valve	1
28	17222000037998	Electronic control box subassembly	1
28.1	12222000012372	Installation plate of electric parts subassembly	1
28.2	17122000062196	Inverter module subassembly	1
28.10	12122000020943	Electronic installing box	1
28.11	17122000062609	Outdoor main control board subassembly	1
28.14	17401203017294	Compressor wire subassembly	1
28.17	12122000014342	Electronic installing box	1
28.21	12122000020942	Air duct	1
29	17222000037997	Terminal board subassembly	1
29.1	17400401003456	Wire joint	1
29.2	12222000015266	Terminal installation subassembly	1
29.3	17122000062420	Inverter module subassembly	1
30	15122000028742	Suction pipe assembly	1
30.1	17400516000850	Pressure switch	1
36	15422000021392	Liquid valve assembly	1
38	17402001000602	Crankcase electric heating strip	1
39	17402002000466	Heater	1
43	15122000026162	Radiator subassembly	1
46	11201007000136	Pipe temperature sensor	1
47	11201007003445	Pipe temperature sensor	1
50	12222000007944	Rear net	1
51	15422000017595	Electronic expansion valve subassembly	1
52	15700101000876	Plate heat exchanger subassembly	1
52.1	15422000017593	Electronic expansion valve subassembly	1
52.1.1	15500213000865	Electric expansive valve	1
53	15123000012887	Evaporator connecting pipe subassembly	1
53	15123000012948	Evaporator connecting pipe subassembly	1
54	16022000C33643	Trademark	1