

MULTI-REFRIGERANT COIL FEATURES

- Factory ready for R-410A installation
- Field-convertible to R-454B with additional field kit and R-454B TXV
- 1.5 to 5 ton nominal sizes

COIL CONSTRUCTION

- **Omniguard™ Total Corrosion Protection*** helps protect against leaks and corrosion for long term performance
- Aluminum tubing, hairpins, distributor and header tubes
- Copper refrigerant sweat connections on both liquid and suction lines for easy brazing

CASING CONSTRUCTION

- Pre-painted heavy gauge steel
- Tightly sealed with wall-to-wall foil-face insulation to ensure <2% air leakage
- Interlocking door assemblies and snug line seal grommets

DRAIN PAN

- Microban® antimicrobial additive to resist mold and mildew growth
- Low water retention minimizing mold and mildew growth
- Compatible with UV lights

EASE OF INSTALL

- Coils exactly match the corresponding furnaces with the same letter designation in the model number
- Preformed duct collar for quick and easy plenum connections
- Refrigerant lines extend outside of the cabinet for easy connection

EASE OF SERVICE

- Removable cabinet panels
- Single protruding dual drain port
- Coil slides out, tubing located at door split, and foil-face insulation for easy cleaning

MULTI-REFRIGERANT COIL OPTIONS

All multi-refrigerant options are cased only

7EC-01

- Dedicated upflow
- Factory installed R-410A TXV for quick installation

7EH-01

- Dedicated horizontal
- Factory installed R-410A TXV for quick installation

7ED-01

- Dedicated downflow
- Factory installed R-410A TXV for quick installation
- Fully supports the furnace without additional bracing

OPTIONAL ACCESSORIES

R-454B COIL CONVERSION KIT (R-410A TO R-454B)

- Complies with UL 60335-2-40 approved standard
- Required for all systems using R-454B refrigerant
- Consists of a refrigerant detection sensor, mounting bracket, A2L labels and installation instructions

R-454B EXPANSION VALVE

- For use with R-454B systems
- Replaces factory installed threaded on TXV, internal to cabinet

WARRANTY

10 year limited parts warranty available when applied with a system. See limited warranty document for details.

7EC-01



7EH-01



7ED-01



NOTE - Coils are furnished with a factory installed threaded R-410A expansion valve. As an option a R-454B expansion valve may be substituted.

NOTE - R-454B Coil Conversion Kit (26Z69) is required with expansion valve substitution and must be ordered separately.

NOTE - Once a coil has been field converted to R-454B, it can no longer be used in R-410A applications.

MULTI-REFRIGERANT EVAPORATOR COILS

MODEL NUMBER GUIDE

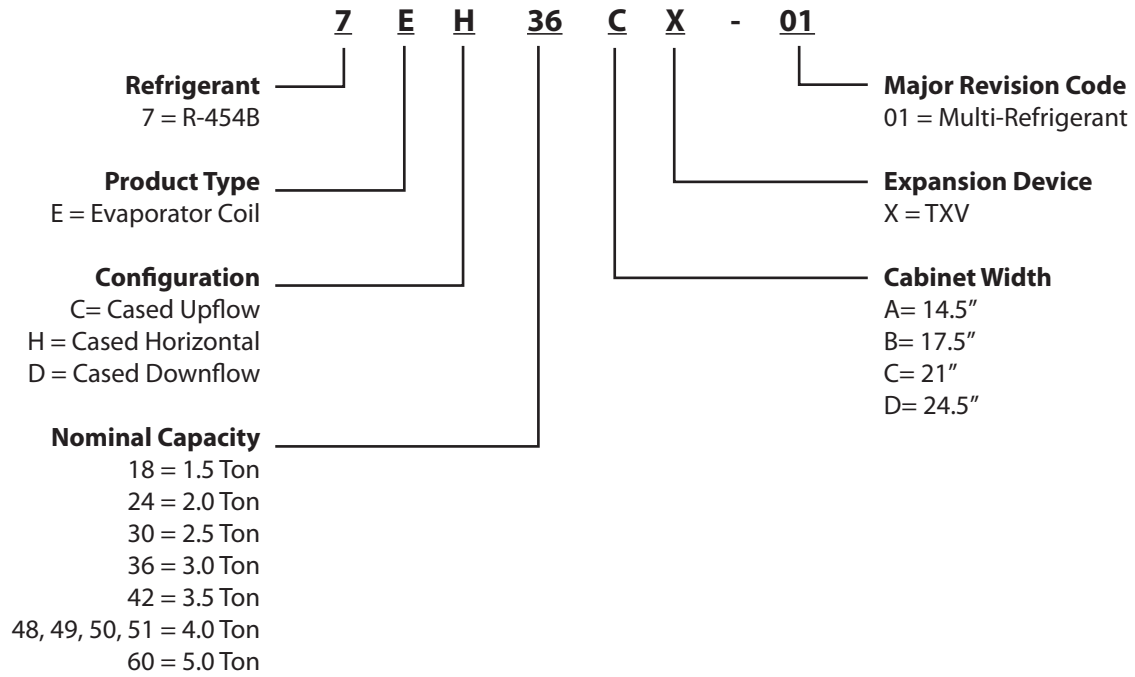

MULTI-REFRIGERANT EVAPORATOR COILS

7EC-01

SPECIFICATIONS					1.5 TO 2 TON
General Data	Model No.	7EC18/24A	7EC18/24B	7EC24A	7EC24B
		Nominal size - Tons	1.5 / 2	1.5 / 2	2
Line Connections in.	Suction / vapor o.d. - sweat	3/4	3/4	3/4	3/4
	Liquid o.d. - sweat	3/8	3/8	3/8	3/8
	Condensate drain (fpt)	(2) 3/4	(2) 3/4	(2) 3/4	(2) 3/4
Shipping Data - lbs.		30	34	38	43

SPECIFICATIONS					2.5 TO 3 TON
General Data	Model No.	7EC30A	7EC30B	7EC30/36A	7EC30/36B
		Nominal size - Tons	2.5	2.5	2.5 / 3
Line Connections in.	Suction / vapor o.d. - sweat	3/4	3/4	3/4	3/4
	Liquid o.d. - sweat	3/8	3/8	3/8	3/8
	Condensate drain (fpt)	(2) 3/4	(2) 3/4	(2) 3/4	(2) 3/4
Shipping Data - lbs.		45	50	41	45

SPECIFICATIONS					2.5 TO 4 TON	
General Data	Model No.	7EC30/36C	7EC36A	7EC36B	7EC48B	7EC48C
		Nominal size - Tons	2.5 / 3	3	3	3.5 / 4
Line Connections in.	Suction / vapor o.d. - sweat	3/4	3/4	3/4	7/8	7/8
	Liquid o.d. - sweat	3/8	3/8	3/8	3/8	3/8
	Condensate drain (fpt)	(2) 3/4	(2) 3/4	(2) 3/4	(2) 3/4	(2) 3/4
Shipping Data - lbs.		48	46	50	55	60

SPECIFICATIONS					
General Data	Model No.	7EC49C	7EC50/60C	7EC60C	7EC60D
		Nominal size - Tons	4	4 / 5	5
Line Connections in.	Suction / vapor o.d. - sweat	7/8	7/8	7/8	7/8
	Liquid o.d. - sweat	3/8	3/8	3/8	3/8
	Condensate drain (fpt)	(2) 3/4	(2) 3/4	(2) 3/4	(2) 3/4
Shipping Data - lbs.		70	60	73	72

MULTI-REFRIGERANT EVAPORATOR COILS

7EC-01

AIR RESISTANCE

Model No.	Air Volume cfm	Total Resistance	
		Dry Coil in. w.g.	Wet Coil in. w.g.
7EC18/24A 7EC18/24B	400	0.06	0.08
	600	0.11	0.17
	800	0.18	0.25
	1000	0.27	0.39
	1200	0.37	0.52
7EC24A	400	0.05	0.05
	600	0.09	0.10
	800	0.16	0.18
	1000	0.23	0.26
	1200	0.32	0.36
7EC24B	400	0.03	0.04
	600	0.07	0.09
	800	0.11	0.15
	1000	0.17	0.22
	1200	0.23	0.31
7EC30A	600	0.07	0.08
	800	0.12	0.13
	1000	0.18	0.20
	1200	0.26	0.28
	1400	0.34	0.37
7EC30B	600	0.06	0.06
	800	0.09	0.11
	1000	0.13	0.16
	1200	0.19	0.23
	1400	0.25	0.31
7EC30/36A	800	0.13	0.14
	1000	0.19	0.21
	1200	0.27	0.30
	1400	0.34	0.39
	1600	0.45	0.51
7EC30/36B 7EC30/36C 7EC36B	800	0.08	0.11
	1000	0.13	0.16
	1200	0.17	0.21
	1400	0.22	0.28
	1600	0.29	0.34

Model No.	Air Volume cfm	Total Resistance	
		Dry Coil in. w.g.	Wet Coil in. w.g.
7EC36A	800	0.13	0.14
	1000	0.19	0.21
	1200	0.27	0.30
	1400	0.34	0.39
	1600	0.45	0.51
7EC48B	1000	0.13	0.13
	1200	0.18	0.18
	1400	0.23	0.24
	1600	0.30	0.31
	1800	0.37	0.40
7EC48C	1000	0.07	0.09
	1200	0.10	0.12
	1400	0.13	0.16
	1600	0.16	0.20
	1800	0.20	0.24
7EC49C	1200	0.08	0.12
	1400	0.13	0.17
	1600	0.17	0.22
	1800	0.22	0.28
	2000	0.28	0.35
7EC50/60C	1200	0.13	0.17
	1400	0.18	0.23
	1600	0.23	0.29
	1800	0.28	0.37
	2000	0.34	0.43
7EC60D	1400	0.11	0.15
	1600	0.14	0.18
	1800	0.17	0.21
	2000	0.21	0.27
	2200	0.25	0.32
7EC60C	2400	0.30	0.37
	1400	0.15	0.19
	1600	0.19	0.23
	1800	0.24	0.28
	2000	0.29	0.34
	2200	0.33	0.40
	2400	0.39	0.46

MULTI-REFRIGERANT EVAPORATOR COILS

7EC-18/24(A/B), -30/36(A/B/C) and -36(A/B) Coils

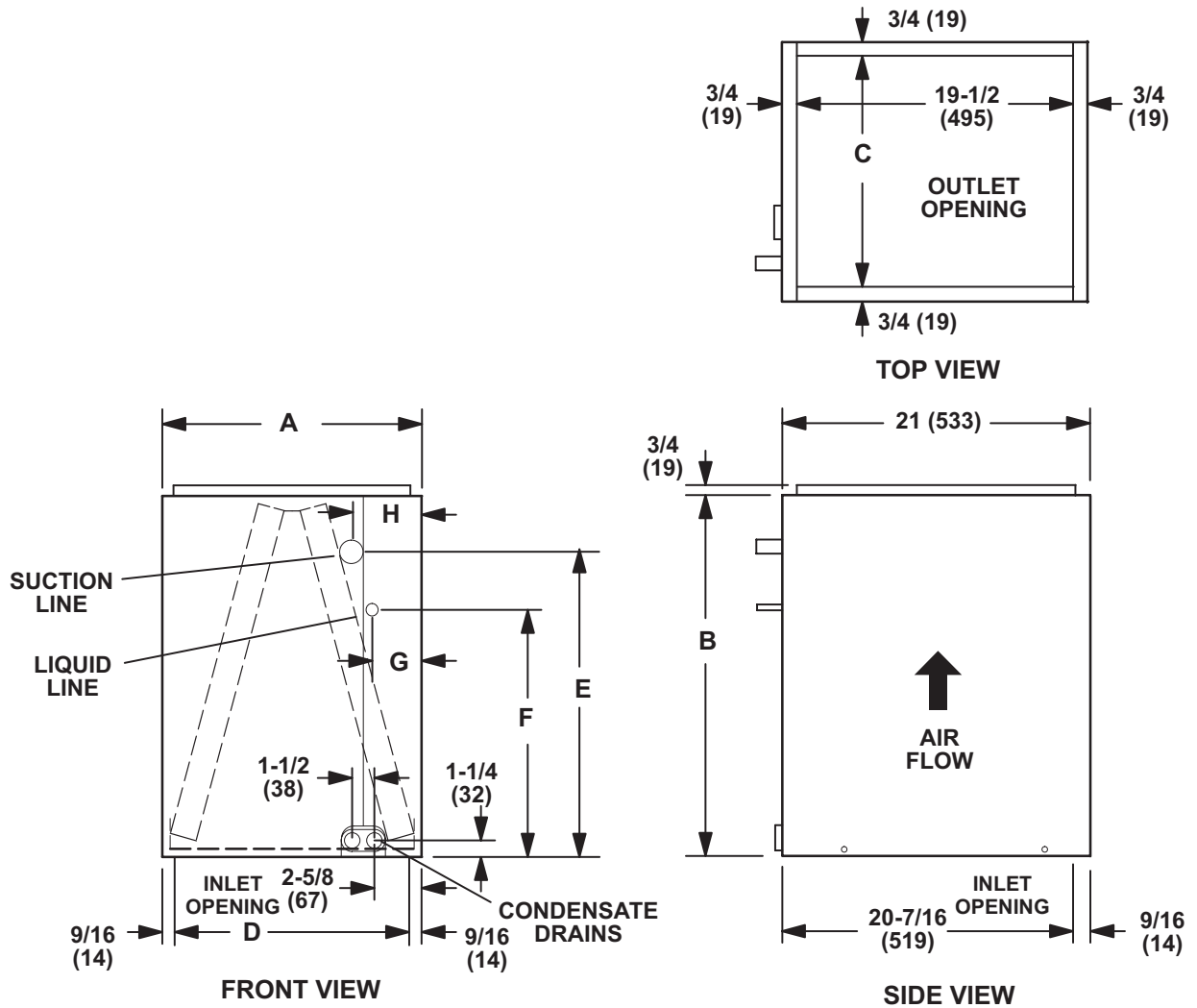

Model Number	A		B		C		D		E		F		G		H	
	in.	mm	in.	mm	in.	mm	in.	mm	in.	mm	in.	mm	in.	mm	in.	mm
7EC18/24A	14-1/2	368	16-1/2	419	13	330	13-3/8	340	7-3/8	187	3-1/2	89	3	76	3-7/8	98
7EC18/24B	17-1/2	445	16-1/2	419	16	406	16-3/8	416	7	178	3-1/2	89	3	76	3-7/8	98
7EC30/36A	14-1/2	368	24-1/2	622	13	330	13-3/8	340	14-1/4	362	4-3/4	121	3	76	3-7/8	98
7EC30/36B	17-1/2	445	24-1/2	622	16	406	16-3/8	416	13-3/8	340	4-3/4	121	3	76	4-1/8	108
7EC30/36C	21	533	24-1/2	622	19-1/2	495	19-7/8	505	14-3/8	365	4-3/4	121	3	76	3-5/8	92
7EC36A	14-1/2	368	24-1/2	622	13	330	13-3/8	340	13-1/2	343	4-3/4	121	2	52	3-1/4	83
7EC36B	17-1/2	445	24-1/2	622	16	406	16-3/8	416	13-3/4	350	4-3/4	121	2-5/8	67	3-7/8	98

MULTI-REFRIGERANT EVAPORATOR COILS

7EC-24(A/B), -30(A/B), -48(B/C), -50/60C and -60D Coils

NOTE- 7EC60D coil is positioned in cabinet with coil face running left to right. All other coil sizes are positioned like drawing.

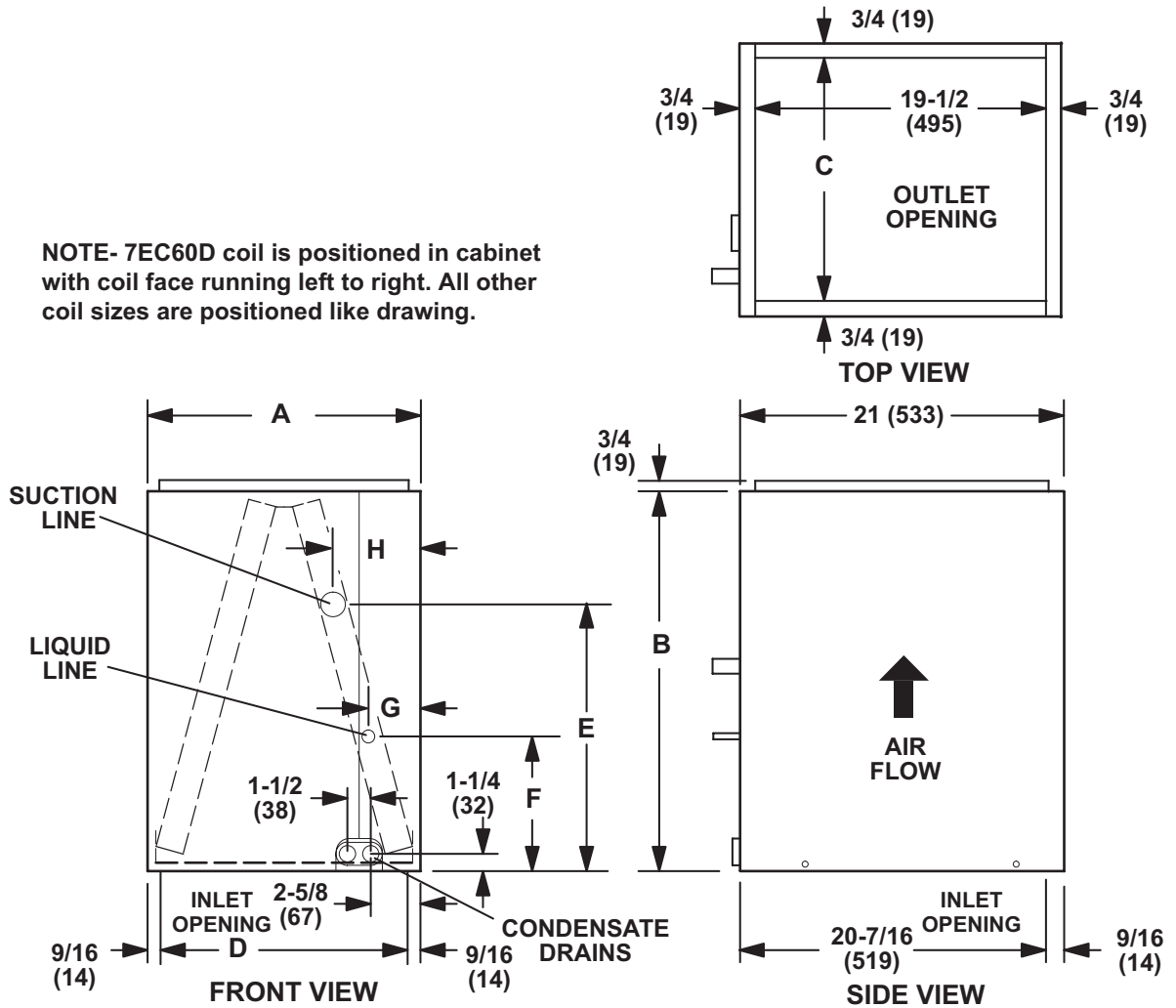

Model Number	A		B		C		D		E		F		G		H	
	in.	mm	in.	mm	in.	mm	in.	mm	in.	mm	in.	mm	in.	mm	in.	mm
7EC24A	14-1/2	368	18-1/2	470	13	330	13-3/8	340	10-1/8	257	3-3/8	86	3	76	3-7/8	98
7EC24B	17-1/2	445	18-1/2	470	16	406	16-3/8	416	10	254	3-1/2	89	3	76	3-7/8	98
7EC30A	14-1/2	368	22-1/2	572	13	330	13-3/8	340	12	305	3-3/8	86	3	76	3-7/8	98
7EC30B	17-1/2	445	22-1/2	572	16	406	16-3/8	416	10-1/2	267	3-3/8	86	3	76	3-7/8	98
7EC48B	17-1/2	445	27-1/2	699	16	406	16-3/8	416	12-7/8	327	3-7/8	98	3	76	4	102
7EC48C	21	533	27-1/2	699	19-1/2	495	19-7/8	505	12-1/2	318	4-3/4	121	2-3/4	70	3-1/2	89
7EC50/60C	21	533	27-1/2	699	19-1/2	495	19-7/8	505	12-1/2	318	4-3/4	121	2-3/4	70	3-1/2	89
7EC60D	24-1/2	622	29-1/2	749	23	584	23-3/8	594	15-1/8	384	4-1/2	121	1-5/8	41	2-5/8	67

MULTI-REFRIGERANT EVAPORATOR COILS

7EC-49C and 7EC-60C

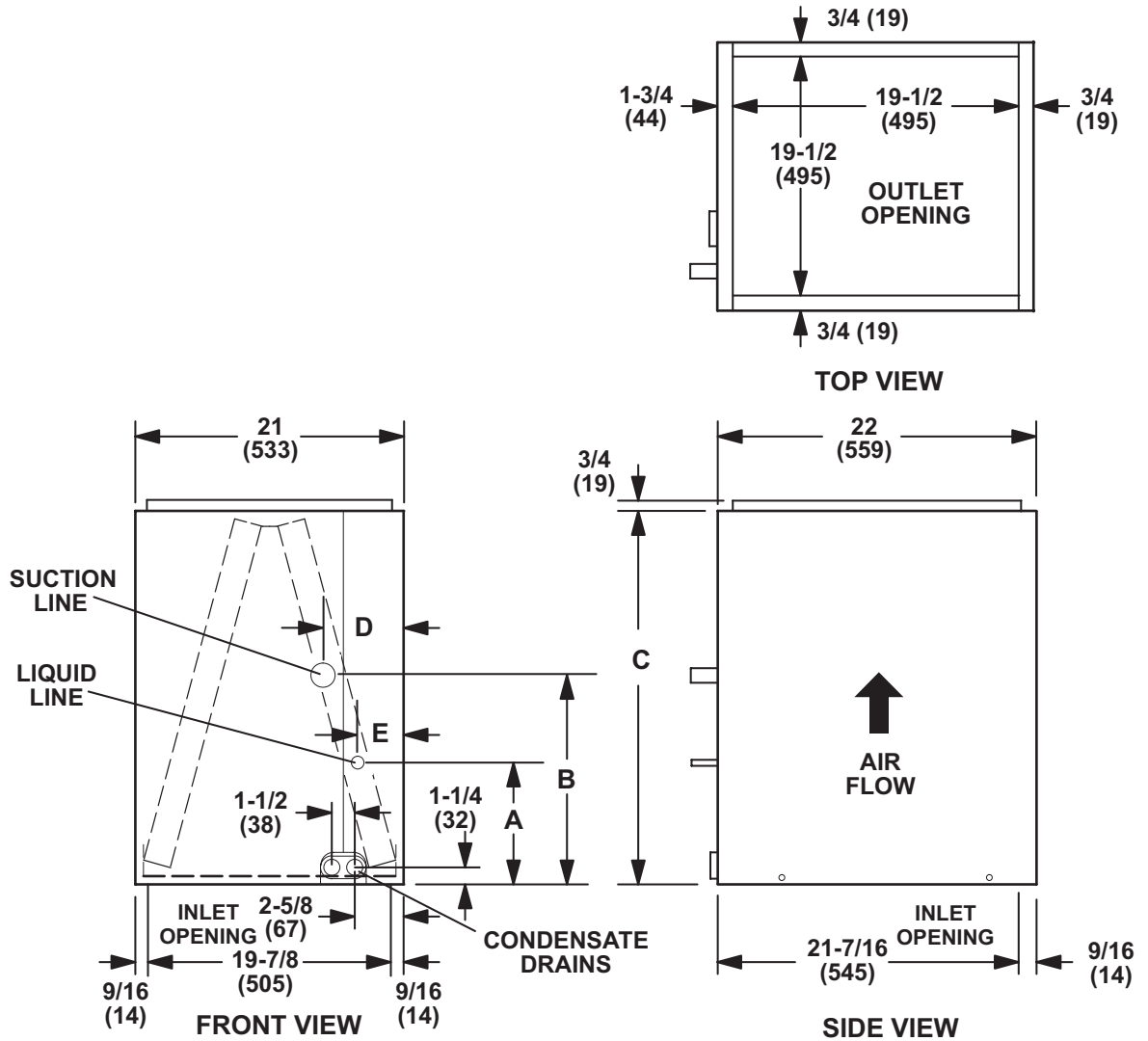

Model Number	A		B		C		D		E	
	in.	mm	in.	mm	in.	mm	in.	mm	in.	mm
7EC49C	4-3/4	121	12-1/8	308	29-1/2	749	3-3/8	86	2-1/2	64
7EC60C	4-3/4	121	14-1/2	368	31-1/2	800	3-3/8	86	2-1/2	64

MULTI-REFRIGERANT EVAPORATOR COILS

7EH-01

SPECIFICATIONS								1.5 TO 3 TON
General Data	Model No.	7EH18A	7EH24A	7EH24B	7EH30A	7EH30B	7EH36A	7EH36B
	Nominal size - Tons	1.5	2	2	2.5	2.5	3	3
Line connections in.	Suction o.d. - sweat	7/8	7/8	7/8	7/8	7/8	7/8	7/8
	Liquid o.d. - sweat	3/8	3/8	3/8	3/8	3/8	3/8	3/8
	Condensate drain (fpt)	(2) 3/4	(2) 3/4	(2) 3/4	(2) 3/4	(2) 3/4	(2) 3/4	(2) 3/4
Shipping Data - lbs.		43	45	49	55	53	47	48

SPECIFICATIONS								3 TO 5 TON
General Data	Model No.	7EH36C	7EH42B	7EH42C	7EH48B	7EH48C	7EH51C	7EH60D
	Nominal size - Tons	3	3.5	3.5	3.5/4	3.5/4	4	5
Line connections in.	Suction o.d. - sweat	7/8	7/8	7/8	7/8	7/8	7/8	7/8
	Liquid o.d. - sweat	3/8	3/8	3/8	3/8	3/8	3/8	3/8
	Condensate drain (fpt)	(2) 3/4	(2) 3/4	(2) 3/4	(2) 3/4	(2) 3/4	(2) 3/4	(2) 3/4
Shipping Data - lbs.		55	66	60	60	59	69	78

MULTI-REFRIGERANT EVAPORATOR COILS

7EH-01

AIR RESISTANCE

Model No.	Air Volume cfm	Total Resistance		Model No.	Air Volume cfm	Total Resistance	
		Dry Coil	Wet Coil			Dry Coil	Wet Coil
		in. w.g.	in. w.g.			in. w.g.	in. w.g.
7EH18A	200	0.02	0.02	7EH36C	800	0.06	0.08
	400	0.05	0.06		1000	0.10	0.13
	600	0.09	0.11		1200	0.15	0.18
	800	0.15	0.17		1400	0.19	0.23
	1000	0.22	0.25		1600	0.24	0.31
7EH24A	400	0.04	0.05		7EH42B	800	0.10
	600	0.09	0.11	1000		0.14	0.18
	800	0.15	0.19	1200		0.20	0.25
	1000	0.23	0.29	1400		0.26	0.31
	1200	0.32	0.40	1600		0.34	0.36
	1400	0.43	0.50	1800		0.42	0.47
7EH24B	400	0.03	0.04	7EH42C	800	0.06	0.06
	600	0.05	0.07		1000	0.09	0.10
	800	0.09	0.11		1200	0.15	0.16
	1000	0.15	0.17		1400	0.18	0.21
	1200	0.21	0.23		1600	0.26	0.28
	1400	0.28	0.30		1800	0.31	0.38
7EH30A	400	0.04	0.05	7EH48B	1000	0.14	0.16
	600	0.09	0.10		1200	0.19	0.23
	800	0.15	0.17		1400	0.25	0.29
	1000	0.24	0.27		1600	0.30	0.38
	1200	0.34	0.38		1800	0.38	0.42
	1400	0.45	0.51		7EH48C	1200	0.16
7EH30B	400	0.02	0.02	1400		0.21	0.26
	600	0.05	0.06	1600		0.27	0.30
	800	0.09	0.11	1800		0.33	0.39
	1000	0.14	0.16	2000		0.39	0.49
	1200	0.19	0.23	7EH51C	1200	0.15	0.16
	1400	0.26	0.30		1400	0.20	0.23
7EH36A	800	0.15	0.18		1600	0.25	0.29
	1000	0.22	0.27		1800	0.31	0.36
	1200	0.30	0.39		2000	0.40	0.44
	1400	0.41	0.48	2200	0.48	0.54	
	1600	0.53	0.63	7EH60D	1400	0.12	0.16
7EH36B	800	0.08	0.10		1600	0.16	0.20
	1000	0.11	0.16		1800	0.20	0.24
	1200	0.16	0.21		2000	0.24	0.30
	1400	0.21	0.27		2200	0.29	0.36
	1600	0.27	0.35		2400	0.34	0.42

MULTI-REFRIGERANT EVAPORATOR COILS

7EH-01

¹ Optional right-hand airflow requires a field fabricated 6 in. (152 mm) spacer in-between the furnace and coil.

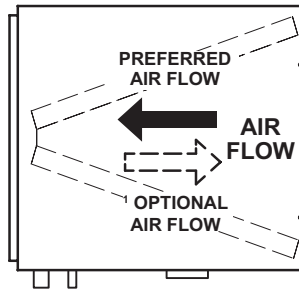

TOP VIEW

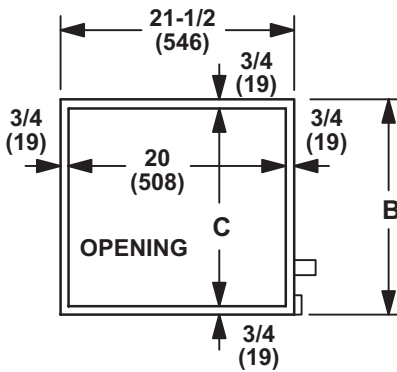

END VIEW

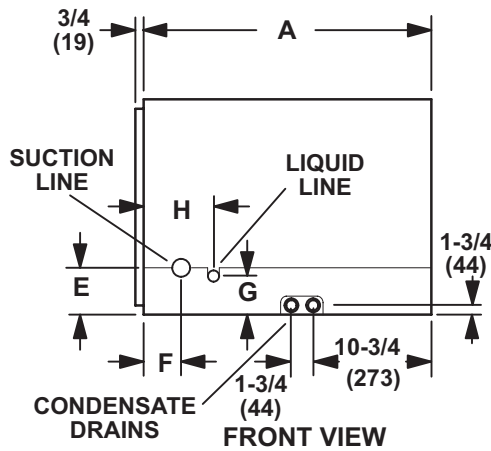

FRONT VIEW

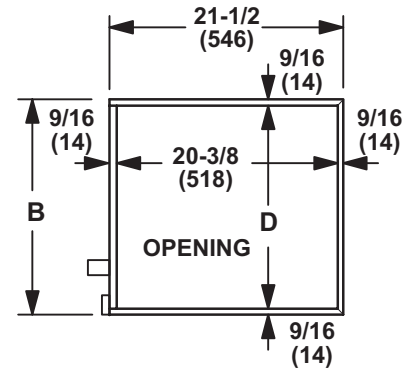

END VIEW

Model No.	A		B		C		D		E		F		G		H	
	in.	mm	in.	mm	in.	mm	in.	mm	in.	mm	in.	mm	in.	mm	in.	mm
7EH18A	26-1/2	673	14-1/2	368	13	330	13-3/8	340	3-3/8	86	2-1/8	54	3-5/8	92	4-7/8	124
7EH24A	26-1/2	673	14-1/2	368	13	330	13-3/8	340	3-3/8	86	2-1/8	54	3-5/8	92	4-7/8	124
7EH24B	26-1/2	673	17-1/2	444	16	406	16-3/8	416	3-3/8	86	2-1/8	54	3-5/8	92	4-7/8	124
7EH30A	31-1/2	800	14-1/2	368	13	330	13-3/8	340	3-3/8	86	2-1/8	54	3-5/8	92	4-7/8	124
7EH30B	26-1/2	673	17-1/2	444	16	406	16-3/8	416	3-3/8	86	2-1/8	54	3-5/8	92	4-7/8	124
7EH36A	26-1/2	673	14-1/2	368	13	330	13-3/8	340	3-3/8	86	2-1/8	54	3-5/8	92	4-7/8	124
7EH36B	26-1/2	673	17-1/2	444	16	406	16-3/8	416	3-3/8	86	2-1/8	54	3-5/8	92	4-7/8	124
7EH36C	26-1/2	673	21	533	19-1/2	495	19-7/8	505	3-3/8	86	2-1/8	54	3-5/8	92	4-7/8	124
7EH42B	31-1/2	800	17-1/2	444	16	406	16-3/8	416	3-3/8	86	2-1/8	54	3-5/8	92	4-7/8	124
7EH42C	26-1/2	673	21	533	19-1/2	495	19-7/8	505	3-3/8	86	2-1/8	54	3-5/8	92	4-7/8	124
7EH48B	31-1/2	800	17-1/2	444	16	406	16-3/8	416	3-3/8	86	2-1/8	54	3-5/8	92	4-7/8	124
7EH48C	26-1/2	673	21	533	19-1/2	495	19-7/8	505	3-3/8	86	2-1/8	54	3-5/8	92	4-7/8	124
7EH51C	31-1/2	800	21	533	19-1/2	495	19-7/8	505	3-3/8	86	2-1/8	54	3-5/8	92	4-7/8	124
7EH60D	31-1/2	800	24-1/2	622	23	584	23-3/8	594	3-3/8	86	2-1/8	54	3-5/8	92	4-7/8	124

MULTI-REFRIGERANT EVAPORATOR COILS

7ED-01

SPECIFICATIONS		1.5 TO 3 TON			
		7ED24A	7ED24B	7ED30/36B	7ED30/36C
General Data	Nominal size - tons	2	2	2.5 / 3	2.5 / 3
Line Connections in. (mm)	Suction / vapor o.d. - sweat	7/8	7/8	7/8	7/8
	Liquid o.d. - sweat	3/8	3/8	3/8	3/8
	Condensate drain (fpt)	(2) 3/4	(2) 3/4	(2) 3/4	(2) 3/4
Indoor Coil	Net face area sq. ft. (m2)	4.08	4.08	4.67	4.67
	Tube diameter - in. (mm)	3/8	3/8	3/8	3/8
	Number of rows	3	3	3	3
	Fins per in. (m)	14	14	14	14
Shipping Weight	lbs. (kg) 1 package	44	51	52	60

SPECIFICATIONS		2.5 TO 5 TON			
		7ED42B	7ED48C	7ED50/60C	7ED60D
General Data	Nominal size - tons	3.5	4	4 / 5	5
Line Connections in. (mm)	Suction / vapor o.d. - sweat	7/8	7/8	7/8	7/8
	Liquid o.d. - sweat	3/8	3/8	3/8	3/8
	Condensate drain (fpt)	(2) 3/4	(2) 3/4	(2) 3/4	(2) 3/4
Indoor Coil	Net face area sq. ft. (m2)	5.83	6.42	7.00	7.00
	Tube diameter - in. (mm)	3/8	3/8	3/8	3/8
	Number of rows	3	3	3	3
	Fins per in. (m)	14	14	14	14
Shipping Weight	lbs. (kg) 1 package	65	69	71	75

MULTI-REFRIGERANT EVAPORATOR COILS

7ED-01

AIR RESISTANCE

Model No.	Air Volume	Total Resistance	
		Dry Coil	Wet Coil
	cfm	in. w.g.	in. w.g.
7ED24A	400	0.08	0.09
	600	0.16	0.18
	800	0.29	0.33
	1000	0.45	0.49
7ED24B	600	0.11	0.13
	800	0.18	0.19
	1000	0.27	0.29
	1200	0.35	0.39
	1400	0.47	0.51
7ED30/36B	600	0.1	0.12
	800	0.15	0.18
	1000	0.24	0.27
	1200	0.32	0.36
	1400	0.43	0.47
7ED30/36C	600	0.05	0.08
	800	0.09	0.12
	1000	0.13	0.17
	1200	0.17	0.23
	1400	0.24	0.30
7ED42B	600	0.08	0.10
	800	0.12	0.14
	1000	0.18	0.22
	1200	0.25	0.30
	1400	0.34	0.39
	1600	0.43	0.49

Model No.	Air Volume	Total Resistance	
		Dry Coil	Wet Coil
	cfm	in. w.g.	in. w.g.
7ED48C	800	0.09	0.10
	1000	0.11	0.13
	1200	0.15	0.18
	1400	0.21	0.23
	1600	0.26	0.30
	1800	0.34	0.37
	2000	0.4	0.44
7ED50/60C	800	0.09	0.11
	1000	0.12	0.14
	1200	0.16	0.20
	1400	0.22	0.24
	1600	0.27	0.32
	1800	0.33	0.38
7ED60D	800	0.09	0.08
	1000	0.13	0.13
	1200	0.18	0.16
	1400	0.16	0.21
	1600	0.2	0.26
	1800	0.24	0.32
	2000	0.29	0.39

MULTI-REFRIGERANT EVAPORATOR COILS

7ED-01

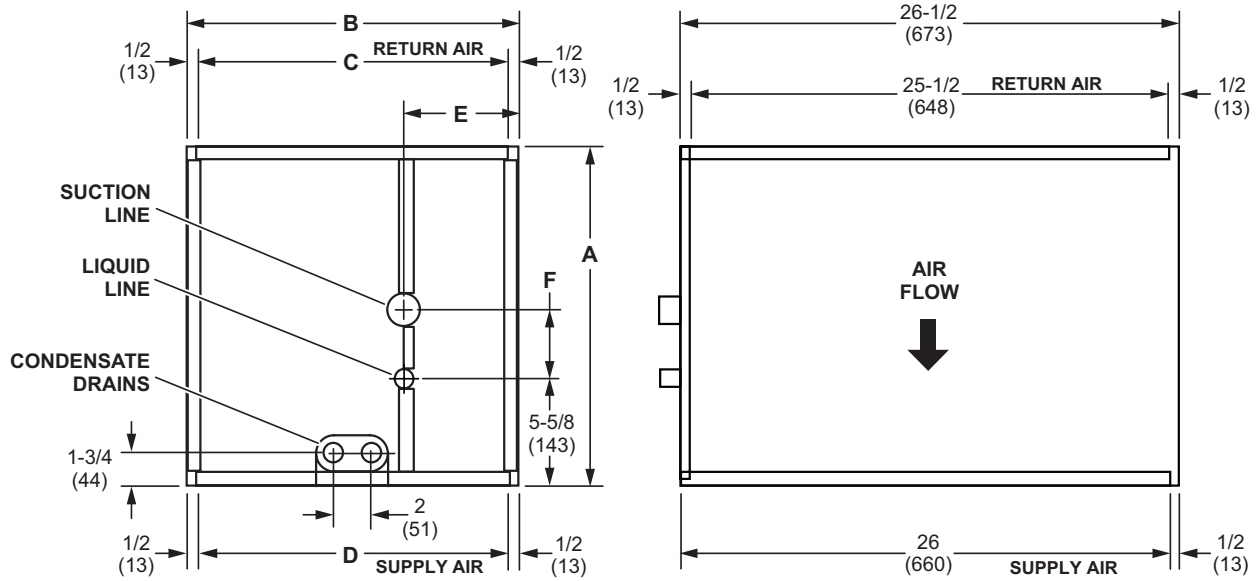

Model Number	A (Height)		B (Width)		C		D		E		F	
	in.	mm	in.	mm	in.	mm	in.	mm	in.	mm	in.	mm
7ED24A	18	457	14-1/2	368	13-1/2	343	13-1/2	343	4-5/8	117	3-5/8	92
7ED24B	18	457	17-1/2	445	16-1/2	419	16-1/2	419	6-1/8	155	3-5/8	92
7ED30/36B	23-1/2	597	17-1/2	445	16-1/2	419	16-1/2	419	6-1/8	155	4-3/4	121
7ED30/36C	23-1/2	597	21	533	20	508	20	508	7-7/8	200	4-3/4	121
7ED42B	23-1/2	597	17-1/2	445	16-1/2	419	16-1/2	419	6-1/8	155	6-3/8	162
7ED48C	27-1/2	699	21	533	20	508	20	508	7-7/8	200	8-5/8	219
7ED50/60C	27-1/2	699	21	533	20	508	20	508	7-7/8	200	10	254
7ED60D	27-1/2	699	24-1/2	622	23-1/2	597	23-1/2	597	9-5/8	244	10-1/2	267

DIMENSIONS - FURNACE/COIL COMBINED DIMENSIONS

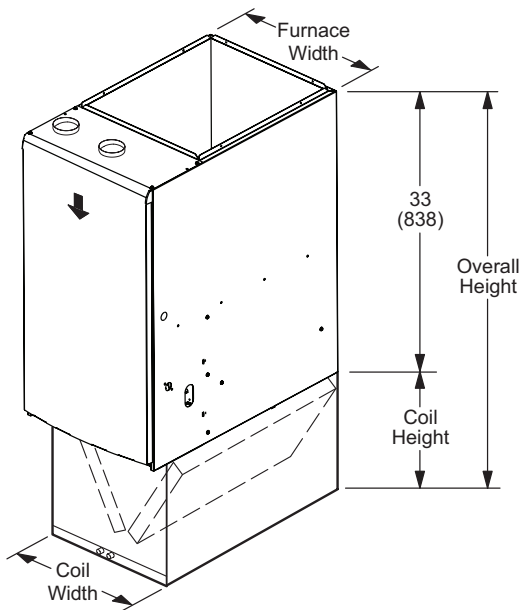

Model Number	Coil Width		Furnace Width		Coil Height		Overall Height	
	in.	mm	in.	mm	in.	mm	in.	mm
7ED24A	14-1/2	368	14-1/2	368	18	457	51	1295
7ED24B	17-1/2	445	17-1/2	445	18	457	51	1295
7ED30/36B	17-1/2	445	17-1/2	445	23-1/2	597	56-1/2	1435
7ED30/36C	21	533	21	533	23-1/2	597	56-1/2	1435
7ED42B	17-1/2	445	17-1/2	445	23-1/2	597	56-1/2	1435
7ED48C	21	533	21	533	27-1/2	699	60-1/2	1537
7ED50/60C	21	533	21	533	27-1/2	699	60-1/2	1537
7ED60D	24-1/2	622	24-1/2	622	27-1/2	699	60-1/2	1537